

 <p>SECURID BUILDING DESIGN BUCURESTI 140/291/2011 Proiectare, Consultanta si Asistenta in Constructii</p>	Beneficiar: M.E.C.S. - U.M.P.M.R.S.U. CONSILIUL LOCAL		Nr. proiect 29L/2011
	Denumire proiect: ADAPTARE LA TEREN A PROIECTULUI DE GRADINITA CU PROGRAM NORMAL CU 3 SALI DE GRUPA Adresa: Sat POIENARI, com POIENARI, judet NEAMT		Faza P.T.+D.E. Revizia 1
	Numele	Semnatura	Scara
Proiectat	arh. Florea A.D.		%
Desenat	arh. Ionescu I.		Oct. 2015
Sef proiect	ing. Popescu C.L.		
PLAN INCADRARE IN ZONA			Plansa nr. A1



Legenda

- Gradinita
- Teren joaca
- Teren sport
- Depozit lemne
- Put
- Punct gospodaresc + platforma spalat pubele
- Spatiu verde
- Trotuar pietonal / drum carosabil
- Gard viu
- Imprejmuire
- Balustrada protectie
- Gradinita de flori
- Remiza PSI
- Cladiri existente
- Teren alocat pentru amplasarea constructiei

Accese

- Acces auto in incinta
- Acces pietonal in incinta
- Acces principal in cladire
- Acces secundar in cladire
- Acces magazine lemne si centrala termica

S teren = 12698 m²
 S incinta amenajata = 1968 m²
 Sc = Sd = 399,4 m²
 POT = 21%
 CUT = 0.18

COTA ±0.00 = 241,40
 C.T.A. = 240,95

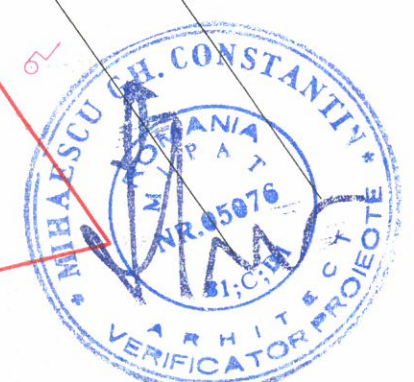

ORDINUL ARHITECTILOR
DIN ROMANIA
5019
Andrei-Daniel
FLOREA
Arhitect cu drept de semnatura

 SICEURD BUILDING DESIGN BUCURESTI J40/251/2011 Proiectare, Consultanta si Asistenta in Constructii	Beneficiar: M.E.C.S. - U.M.P.M.R.S.U. CONSILIUL LOCAL		Nr. proiect 29L/2011
	Denumire proiect: ADAPTARE LA TEREN A PROIECTULUI DE GRADINITA CU PROGRAM NORMAL CU 3 SALI DE GRUPA		Faza P.T.+D.E. Revizia 1
Adresa: Sat POIENARI, com POIENARI, judet NEAMT		Plansa nr. A2	
	Numele	Semnatura	Scara
Proiectat	arh. Florea A.D.		1:500
Desenat	arh. Ionescu I.		Oct. 2015
Sef proiect	ing. Popescu C.L.		

PLAN DE SITUATIE

ARHITECTURA SI URBANISTICA

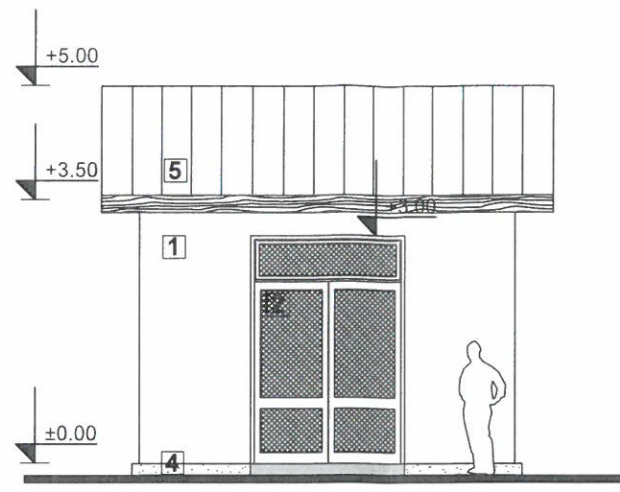

FATADA PRINCIPALA
scara 1:100

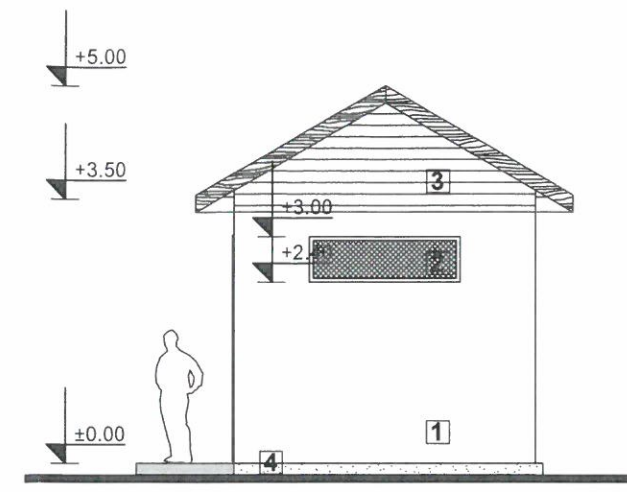

FATADA LATERALA
scara 1:100

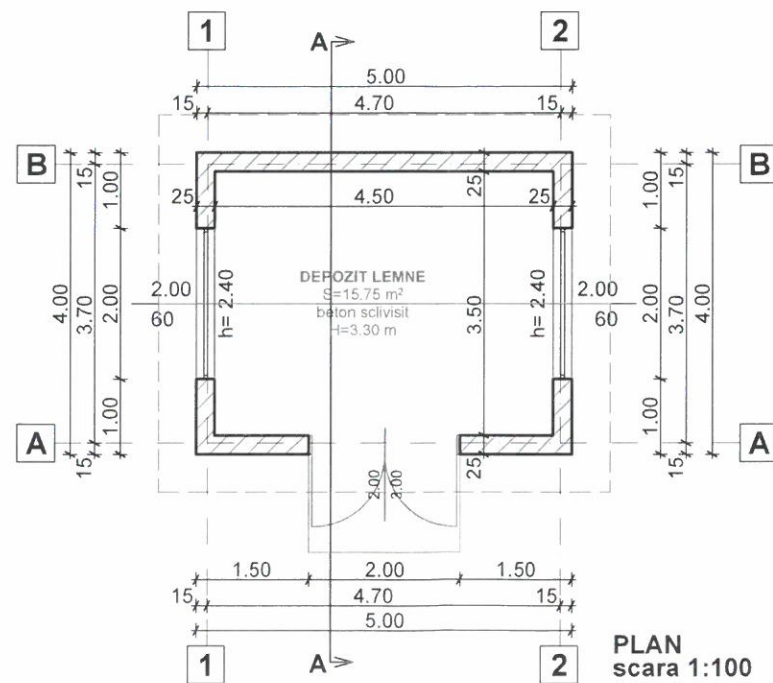



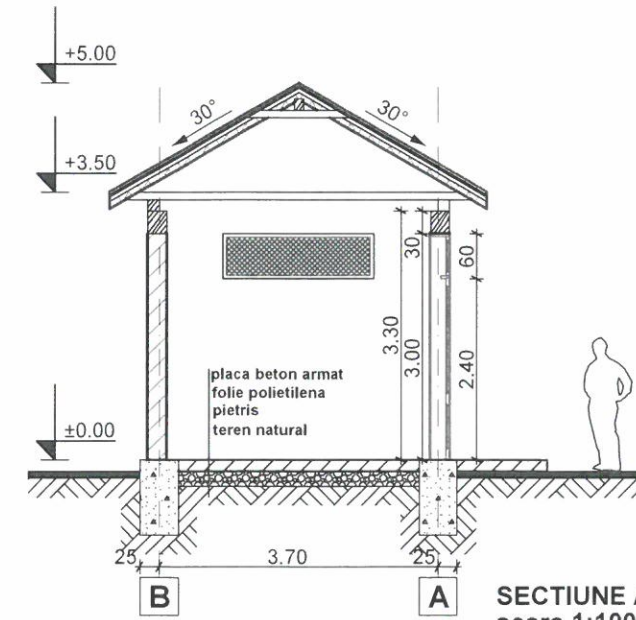

PLAN
scara 1:100



SECTIUNE A-A
scara 1:100

- 1 TENCUIALA DRISCUITA + ZUGRAVEALA LAVABILA - culoare alba
- 2 TAMPLARIE METALICA CU PLASA DE SARMA - culoare maro-roscat
- 3 ASTEREA LA BAITUIA - culoare maro-roscat
- 4 SOCLU MOZAIK SPALAT - culoare maro-roscat
- 5 INVELITOARE METALICA TIP 'LINDAB' - culoare maro-roscat



 <p>SECUR BUILDING INTERIOR BUCURESTI 140 / 291 / 2011</p> <p>Proiectare, Consultanta si Asistenta in Constructii</p>	Beneficiar: M.E.C.S. - U.M.P.M.R.S.U. CONSILIUL LOCAL		Nr. proiect 29L/2011
	Denumire proiect: ADAPTARE LA TEREN A PROIECTULUI DE GRADINITA CU PROGRAM NORMAL CU 3 SALI DE GRUPA		Faza P.T.+D.E. Revizia 1
Adresa: Sat POIENARI, com POIENARI, judet NEAMT		Plansa nr. A3	
	Numele	Semnatuura	Scara
Proiectat	arh. Florea A.D.		1:100
Desenat	arh. Ionescu I.		Oct. 2015
Sef proiect	ing. Popescu C.L.		

VEDERE POARTA ACCES AUTO SC. 1:50

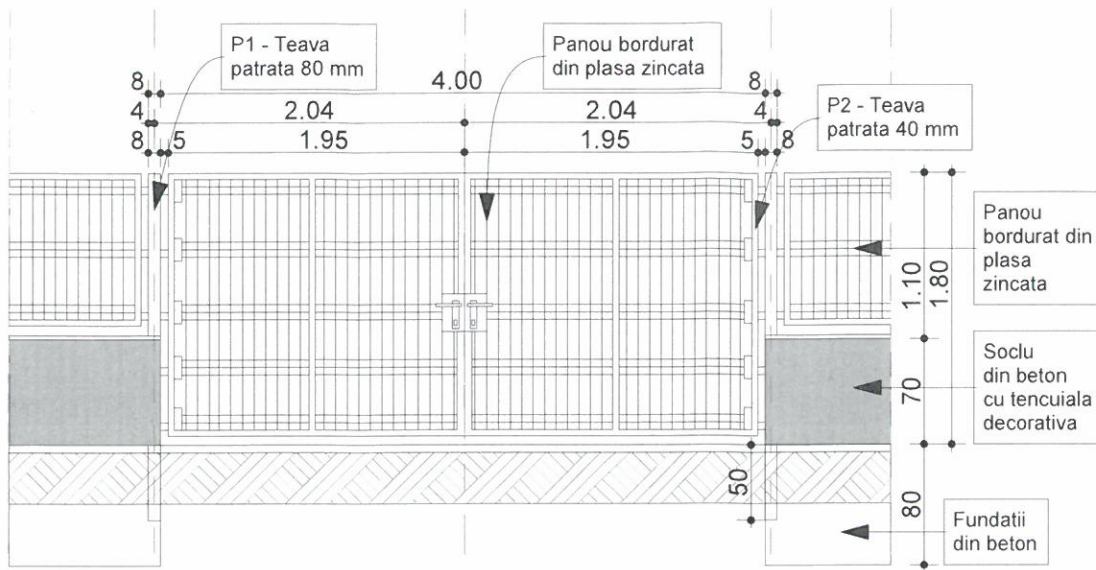

PANOU
FIX

POARTA ACCES
AUTO

PANOU
FIX

VEDERE POARTA PIETONAL SC. 1:50

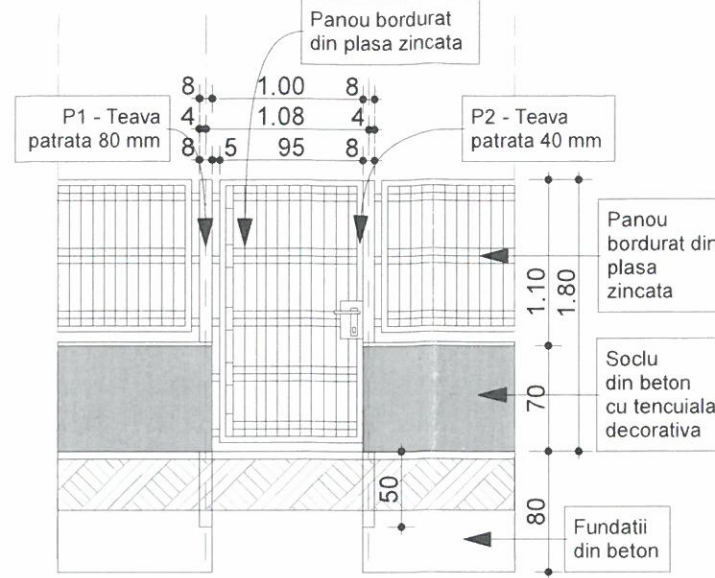

PANOU
FIX

POARTA
PIETONALA

PANOU
FIX

VEDERE PANOU FIX SC. 1:50

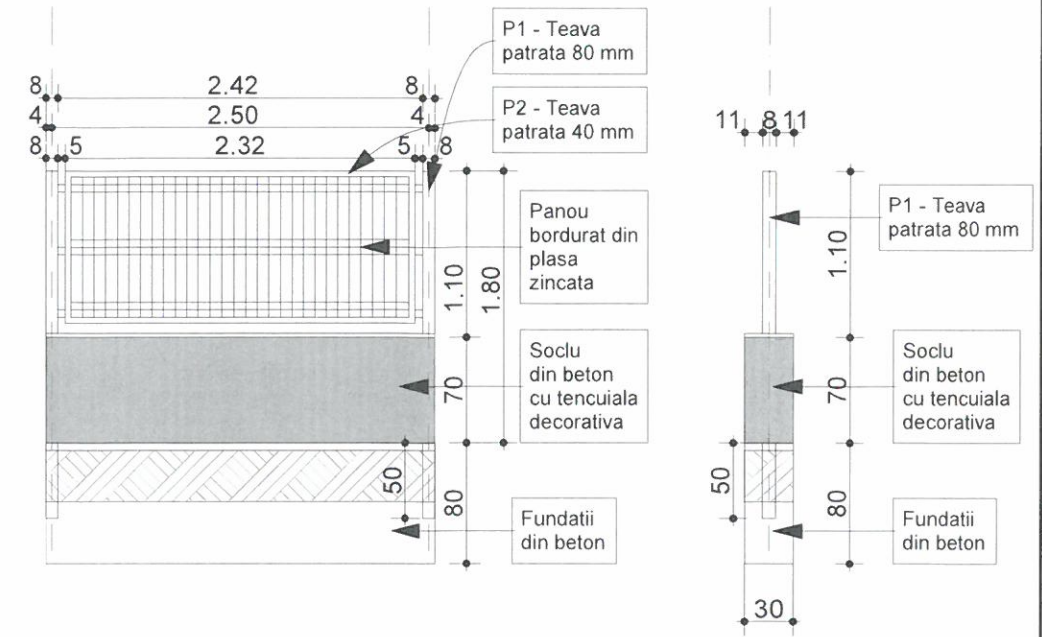

PANOU
FIX

PANOU
FIX

PLAN POARTA ACCES AUTO SC. 1:50

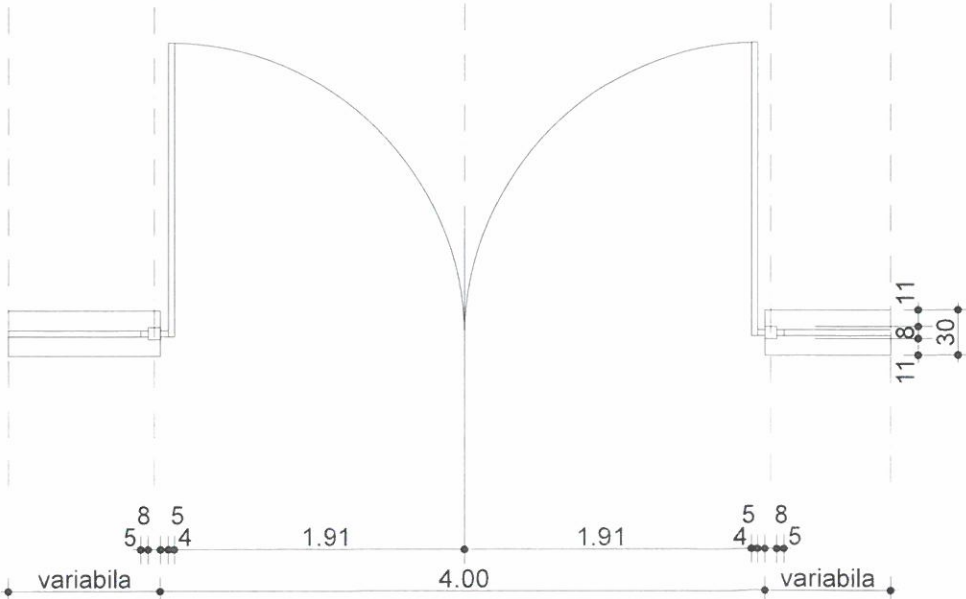

PLAN POARTA PIETONAL SC. 1:50

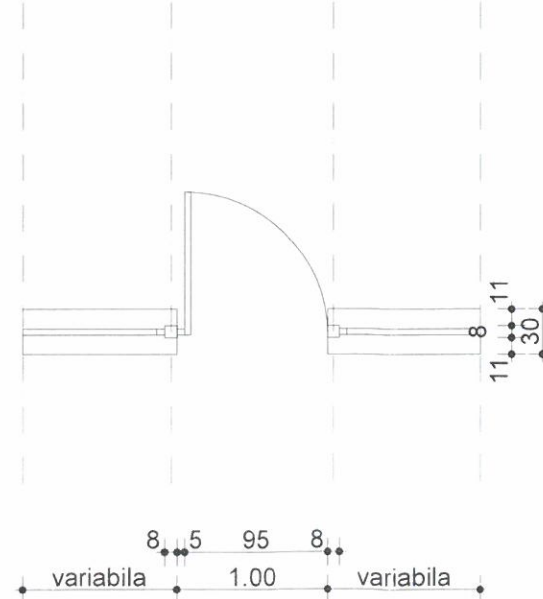

PLAN PANOU FIX SC. 1:50

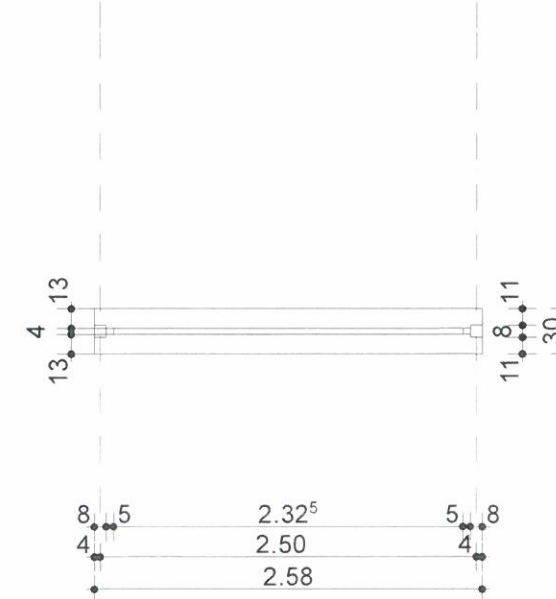

ORDINUL ARHITECTILOR
DIN ROMANIA
5019
Andrei-Daniel
FLOREA
Arhitect cu drept de semnatura

 <p>SECURID BUIDING INTELSERIE BUCURESTI J40 / 251 / 2011</p>		<p>Beneficiar: M.E.C.S. - U.M.P.M.R.S.U. CONSILIUL LOCAL</p>		<p>Nr. proiect 29L/2011</p>	
<p>Proiectare, Consultanta si Asistenta in Constructii</p>		<p>Denumire proiect: ADAPTARE LA TEREN A PROIECTULUI DE GRADINITA CU PROGRAM NORMAL CU 3 SALI DE GRUPA</p>		<p>Faza P.T.+D.E. Revizia 1</p>	
<p>Adresa: Sat POIENARI, com POIENARI, judet NEAMT</p>		<p>Scara 1:50</p>		<p>Planşa nr. A4</p>	
Proiectat	arh. Florea A.D.	Semnatura		<p>DETALIU POARTA ACCES AUTO SI PIETONALA</p>	
Desenat	arh. Ionescu I.	Semnatura		<p>Oct. 2015</p>	
Sef proiect	ing. Popescu C.L.	Semnatura			

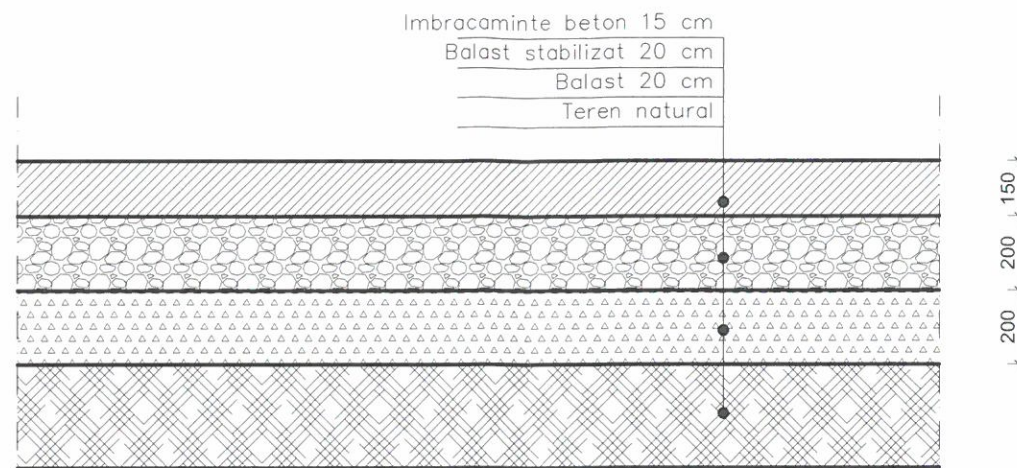

DETALIU – PLATFORMA GOSPODAREASCA – SC. 1/20

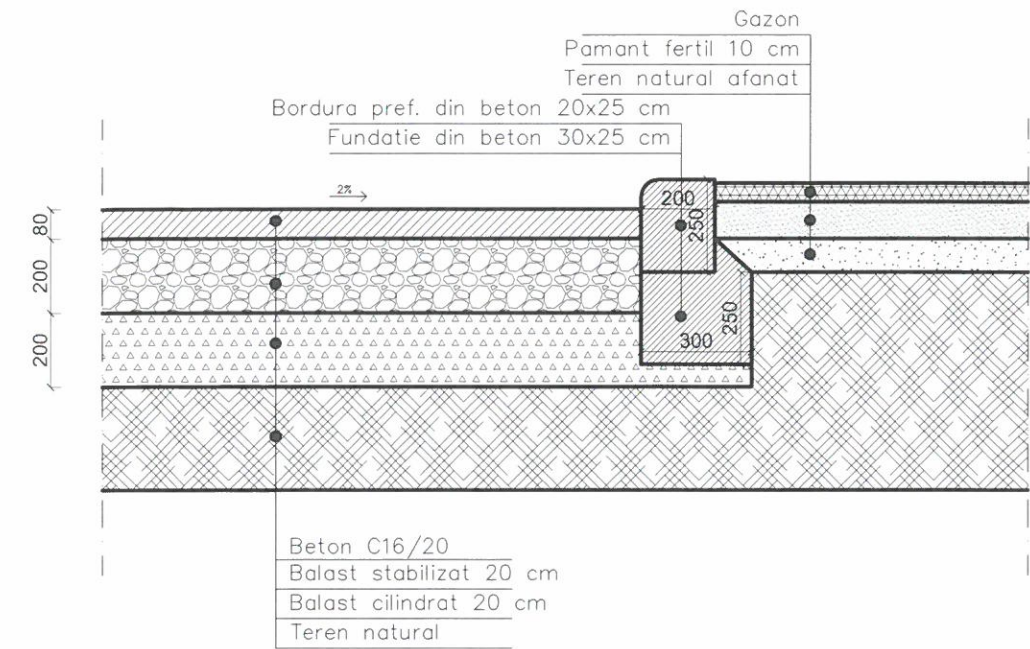

DETALIU – ALEE CAROSABILA – SC. 1/20

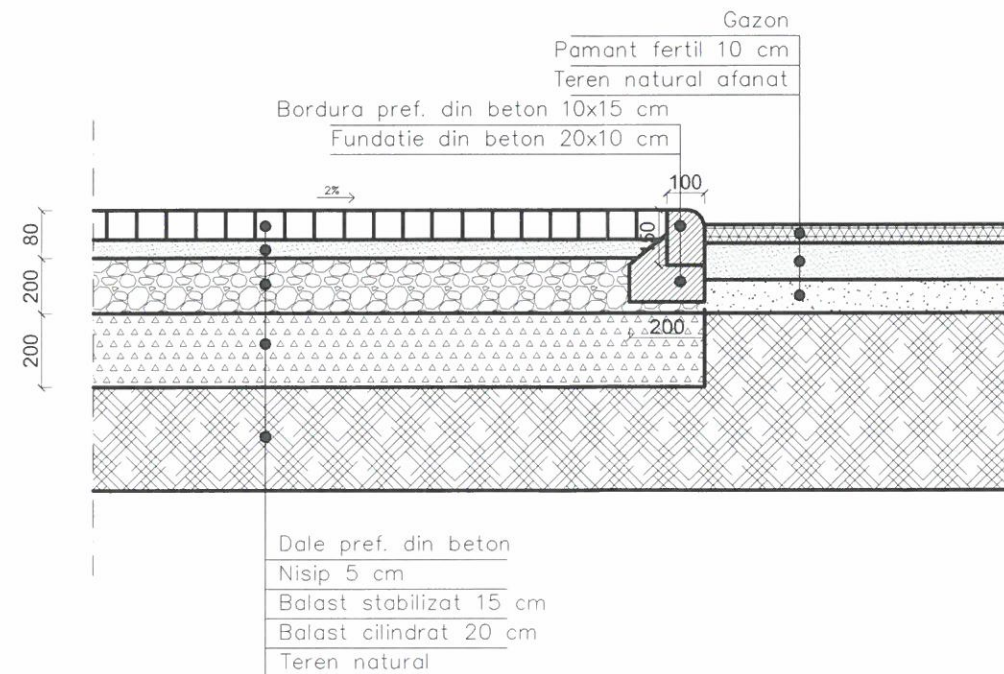

DETALIU – ALEE PIETONALA – SC. 1/20



Proiectant: S.C. BUREAU DE PROIECTARE SI CONSULTANTA S.R.L. BUCURESTI Proiectare, Consultanta si Asistenta in Constructii			Beneficiar: M.E.C.S. - U.M.P.M.R.S.U. CONSILIUL LOCAL Denumire proiect: ADAPTARE LA TEREN A PROIECTULUI DE GRADINITA CU PROGRAM NORMAL CU 3 SALI DE GRUPE Sat POIENARI, com POIENARI, judet NEAMT		Nr. proiect 29L/2011 Faza P.T.+D.E. Revizia 1
Proiectat Desenat Sef proiect	Numele arh. A. D. Florea arh. I. Ionescu ing. C. Popescu	Semnatura 	Scara 1:20 oct. 2015	Titlu proiect: DETALII AMENAJARI EXTERIOARE Plansa nr. A5	

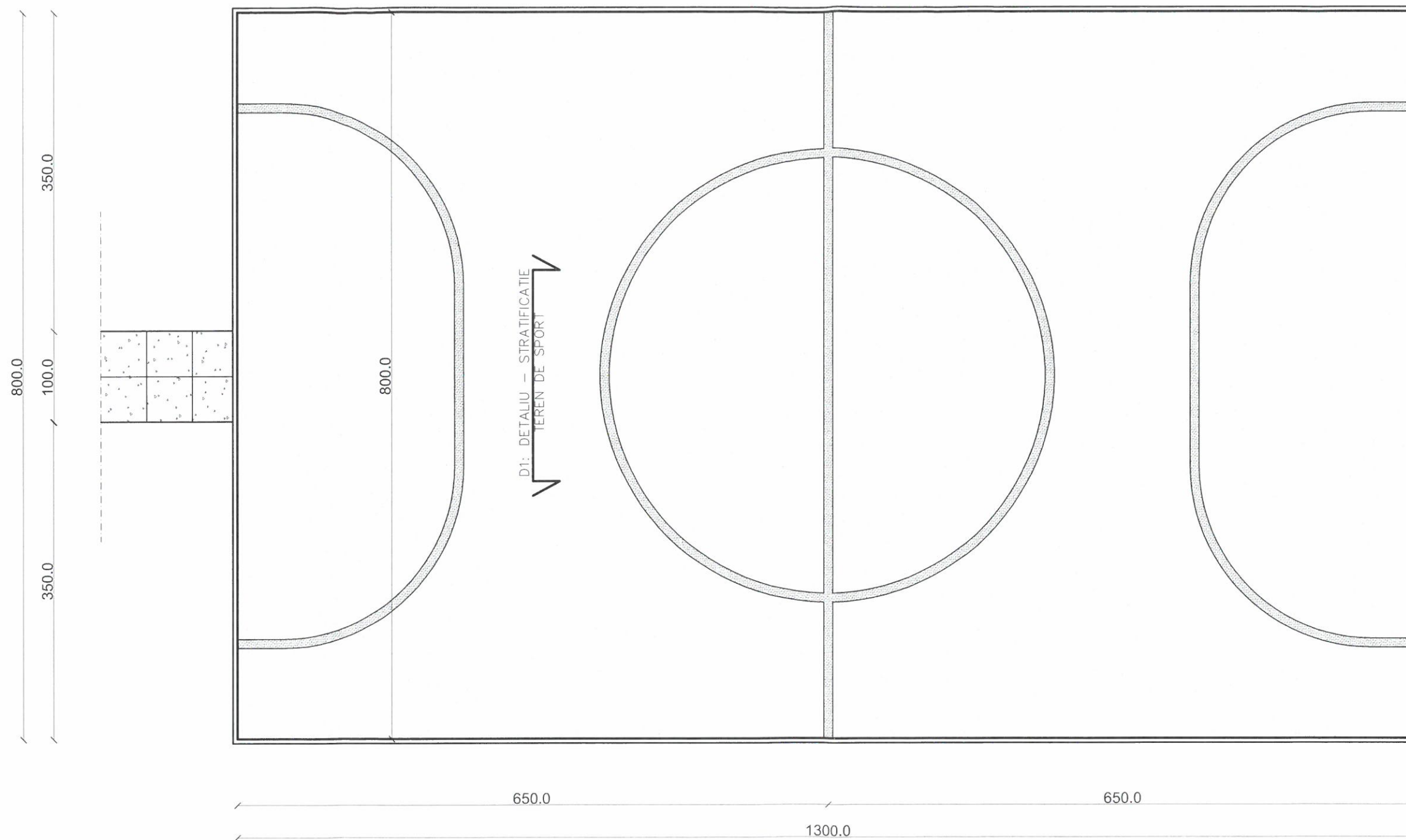

ORDINUL ARHITECTILOR
DIN ROMANIA
5019
Andrei-Daniel
FLOREA
Arhitect cu drept de semnatura

PLAN TEREN DE JOC – SC. 1:50

Proiectant: STUDIO BUIUC INTERIOR BUCURESTI 10/25/2015 Proiectare, Consultanta si Asistenta in Constructii				Beneficiar: M.E.C.S. - U.M.P.M.R.S.U. CONSILIUL LOCAL		Nr. proiect 29L/2011
				Denumire proiect: ADAPTARE LA TEREN A PROIECTULUI DE GRADINITA CU PROGRAM NORMAL CU 3 SALI DE GRUPA Sat POIENARI, com POIENARI, judet NEAMT		Faza P.T.+D.E. Revizia 1
	Numele	Semnatura	Scara	Titlu proiect:		Plansa nr. A6
Proiectat	arh. A. D. Florea		1:50	PLAN TEREN DE JOC		
Desenat	arh. I. Ionescu		oct. 2015			
Sef proiect	ing. C. Popescu					

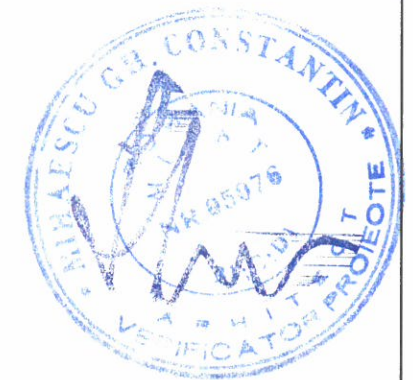
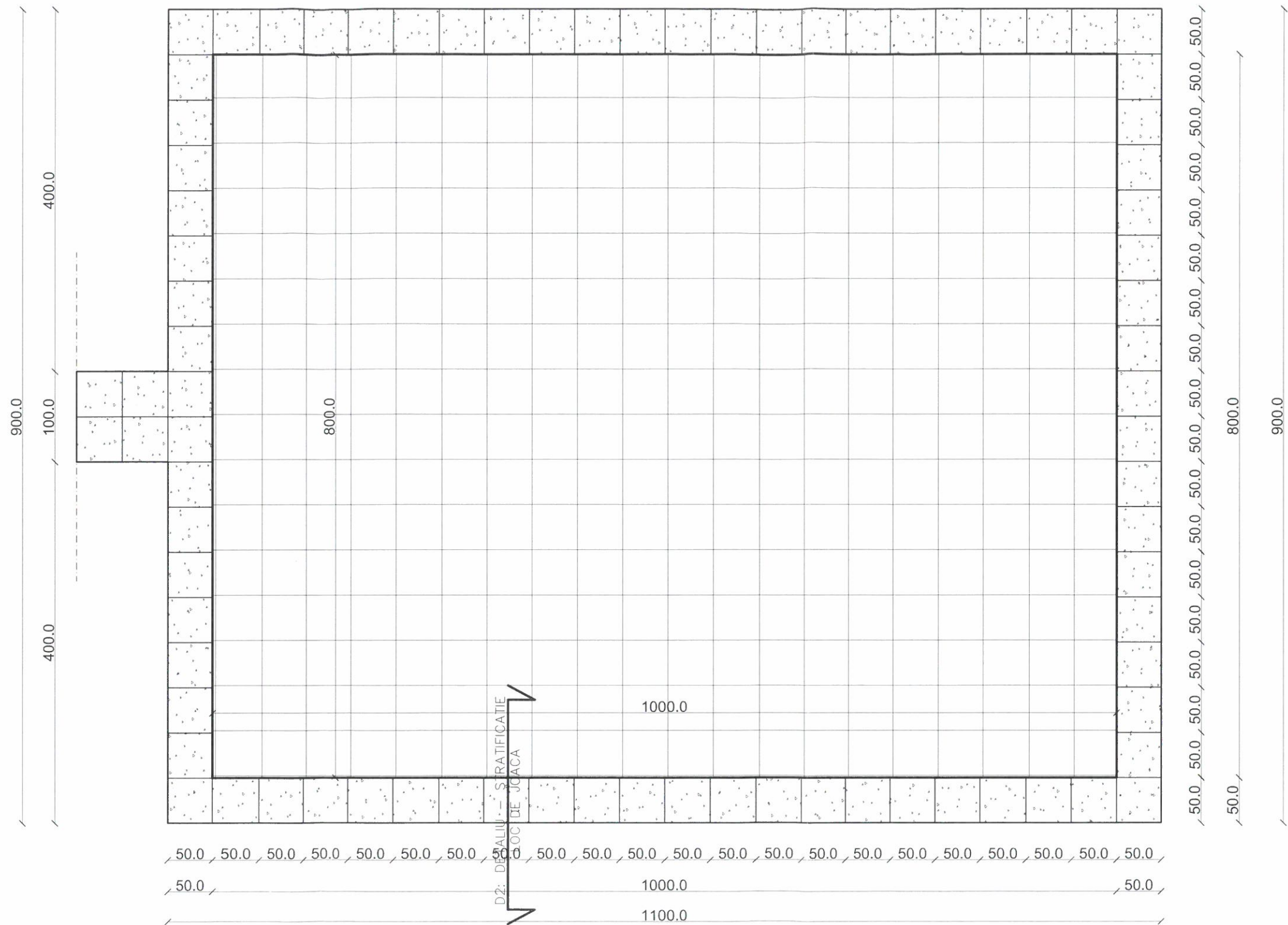

PLAN LOC DE JOACA – SC. 1:50

Proiectant: SERGIU BUILDING INTECH SRL BUCURESTI 10/25/2011 Proiectare, Consultanta si Asistenta in Constructii			Beneficiar: M.E.C.S. - U.M.P.M.R.S.U. CONSILIUL LOCAL	Nr. proiect 29L/2011
Denumire proiect: ADAPTARE LA TEREN A PROIECTULUI DE GRADINITA CU PROGRAM NORMAL CU 3 SALI DE GRUPA Sat POIENARI, com POIENARI, judet NEAMT			Faza P.T.+D.E. Revizia 1	
Titlu proiect: PLAN LOC DE JOACA			Plansa nr. A7	
Proiectat	arh. A. D. Florea	Semnatura 	Scara 1:50	
Desenat	arh. I. Ionescu		oct. 2015	
Sef proiect	ing. C. Popescu			

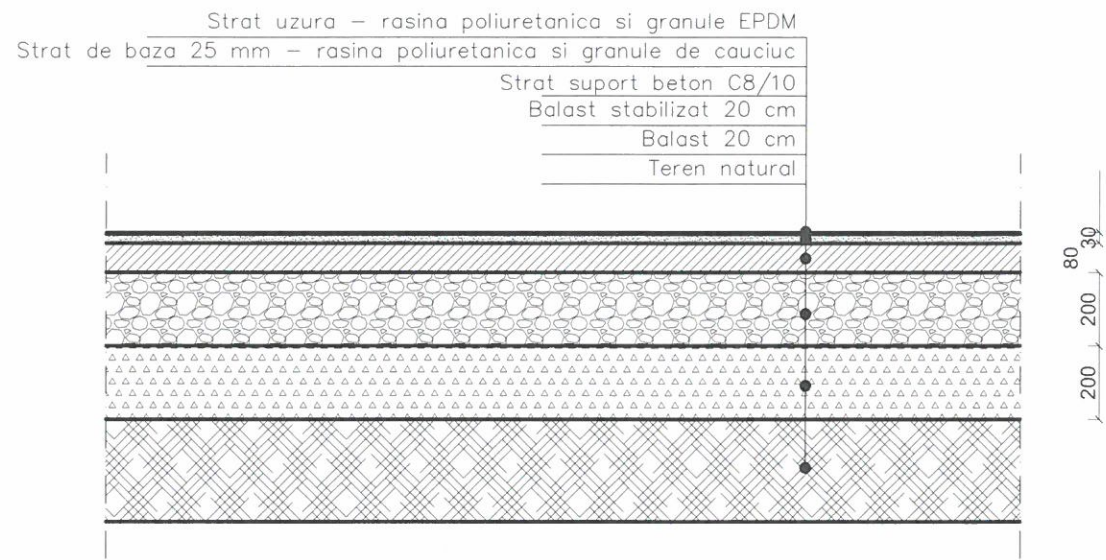

D1: DETALIU – STRATIFICATIE TEREN DE SPORT – SC. 1/20

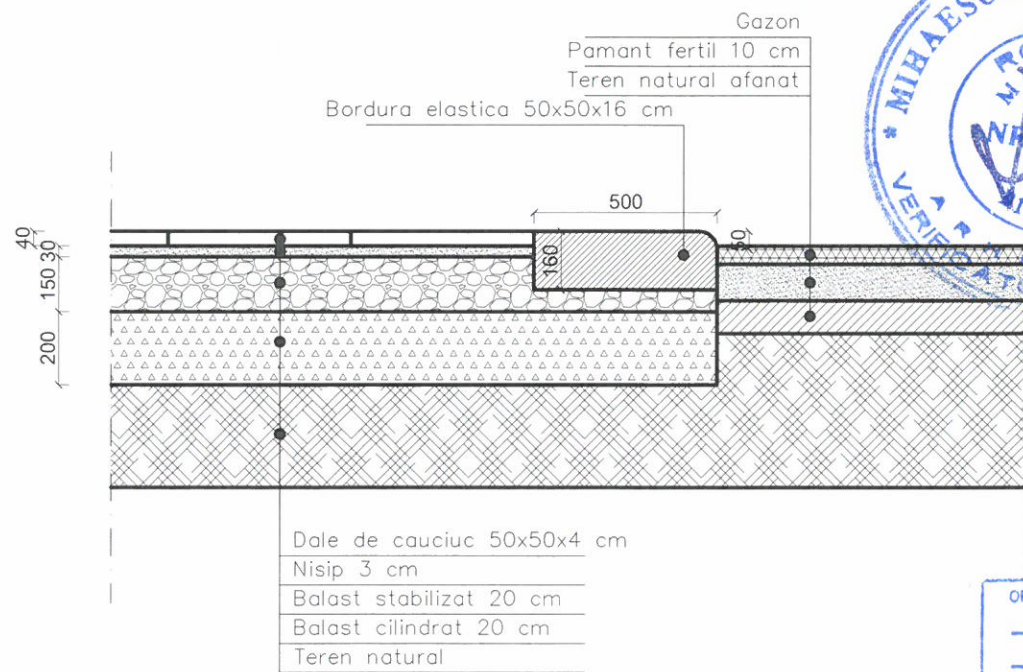

ORDINUL ARHITECTILOR
 DIN ROMANIA
 5019
**Andrei-Daniel
 FLOREA**
 Arhitect cu drept de semnatura

D2: DETALIU – STRATIFICATIE LOC DE JOACA – SC. 1/20

Proiectant: Proiectare, Consultanta si Asistenta in Constructii		Beneficiar: M.E.C.S. - U.M.P.M.R.S.U. CONSILIUL LOCAL		Nr. proiect 29L/2011	
Denumire proiect: ADAPTARE LA TEREN A PROIECTULUI DE GRADINITA CU PROGRAM NORMAL CU 3 SALI DE GRUPA Sat POIENARI, com POIENARI, judet NEAMT		Faza P.T.+D.E. Revizia 1			
Titlu proiect: DETALII SUPRAFETE DE JOC		Plansa nr. A8			
	Numele	Semnatura	Scara		
Proiectat	arh. A. D. Florea		1:20		
Desenat	arh. I. Ionescu		oct. 2015		
Sef proiect	ing. C. Popescu				